

**Tipo PHW / PHW-HD per il trasporto di tubi in posizione orizzontale**

PHW / PHW-HD type for transportation of pipes in horizontal position

- Suitable for transportation of steel and concrete pipes in horizontal position.
- Special plastic coating, pressure resistant, to not damage the pipes.
- Always use in pairs.
- Safety factor min. 5 x rated load capacity.
- Idonei per il trasporto in orizzontale di tubi metallici o di cemento.
- Rivestimento plastico, resistente alla pressione, per non danneggiare il tubo.
- Utilizzare esclusivamente in coppia.
- Coefficiente sicurezza 5 volte minimo la portata nominale.

Tipo Type	Portata* WLL*	Luce di presa Jaw opening		Dimensioni Dimensions							Peso** Weight**
		kg	R mm	V mm	S mm	W mm	U mm	T mm	X mm	Y mm	
PHW 1,5 t	1.500	40	120	70	50	185	16	41	25	2	
PHW 3 t	3.000	40	120	70	50	185	16	41	25	2	
PHW 4 t	4.000	50	140	70	58	204	26	41	25	3	
PHW 6 t	6.000	50	140	70	58	204	26	41	25	3	
PHW 8 t	8.000	70	140	70	58	224	26	45	25	3,70	
PHW 10 t	10.000	70	140	70	58	224	26	85	45	7	
PHW 12 t	12.000	70	140	70	58	224	26	85	45	7	
PHW 15 t	15.000	70	155	70	76	250	26	100	60	9	
PHW 20 t	20.000	70	155	70	76	250	26	100	60	9	
PHW-HD 5 t	5.000	60	271	100	85	230	26	80	20	6,70	
PHW-HD 10 t	10.000	60	271	100	85	230	26	80	30	9,70	
PHW-HD 20 t	20.000	60	291	100	105	269	36	80	35	14	
PHW-HD 30 t	30.000	60	309	100	115	293	43	80	40	19	
PHW-HD 60 t	60.000	60	309	100	115	313	62	80	60	35	

\* Per una coppia di morse. Portata con angolo al vertice dell'imbracatura 60°.

\*\* Peso di una morsa.

\* Capacity of a pair of clamps. Capacity with top angle 60° max.

\*\* Weight of one clamp.

**PHW**

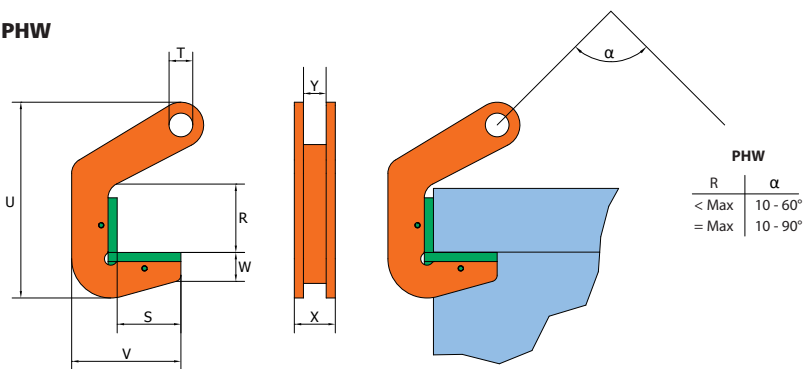

**PHW-HD**

